

Model 05

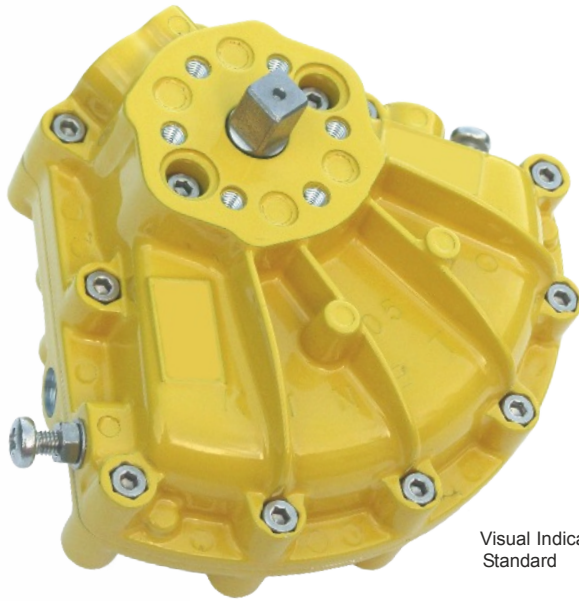

Visual Indicator Standard

Standard Coupling
(supplied with actuator weight 0.09 lbs/0.04 kg)

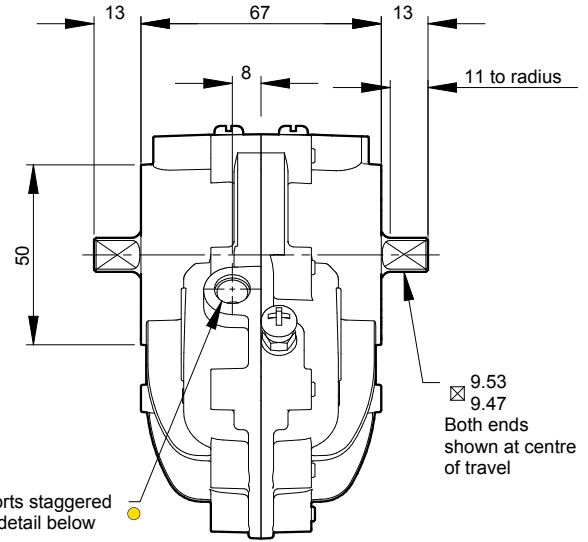
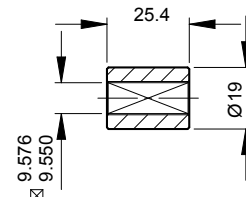

Specification

Output Torque

440 lbf ins/50 Nm
at 100 psi/7 bar

Angle of Travel (adjustable)

84° - 100°
(restricted travel versions available)

Displaced Volume

6.9 in³/113 cm³

Finish

Epoxy stove enamel

Weight

2.73 lb/1.24 kg
(excluding coupling)

For further information see General Specification on page 50.

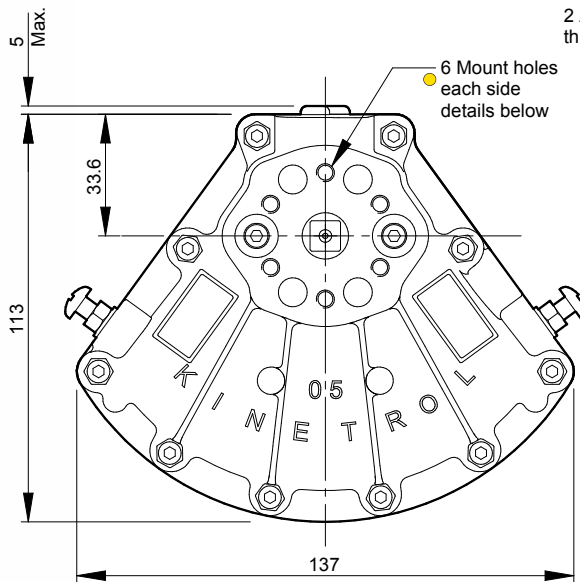

Model	Air Ports	Mount Holes
054-100	G ¹ / ₈	6 x M5 x 10 deep on 34.9 PCD
057-100	1/ ₈ NPT	6 x 10-24 UNC x 0.39" deep on 1.375" PCD

Options

- Fail safe spring return units - clockwise or counter clockwise see pages 5-7
- Limit switch boxes for open/close indication - various switches for hazardous areas see pages 9-12
- Integral solenoid valve see page 20
- AP pneumatic positioner - full range of options see pages 17/18
- EL electropneumatic positioner - full range of options see pages 15/16
- P3 on/off positioner- full range of options including hazardous area see pages 21-23
- Clear Cone position monitor see page 20
- 180° model see pages 25/26
- Female drive and mounting details to DIN 3337 and ISO 5211 see page 50
- ISO adaptor see page 8
- Spring to centre see page 24
- Geared manual override see page 46
- Code identification see page 62
- Torque outputs see pages 58-60
- See pages 49-52 for English dimensions and dimensions of spring options
- High temperature / Low temperature options see page 50

